

*Stay on the
right track*



GEOGRIP
Pads for Excavators

A WORLD LEADER IN THE RUBBER INDUSTRY

Bridgestone was founded in 1931 and has grown to become the world's largest tire and rubber products company, with 179 production facilities in 25 countries and sales networks in over 150 countries.

The company is renowned for its R&D and design capability, exemplified by the success of Bridgestone's racing tires. This expertise extends to a wide range of products including automotive parts and industrial rubber products such as GEOGRIP.

"Bridgestone... Serving Society with Superior Quality"

Advantages of **GEOGRIP**

GEOGRIPs are individually vulcanised rubber pads with internal core metals. They are easily fitted to the undercarriage of excavators and other machines in the same way as conventional steel shoes. GEOGRIPs are a good alternative to large steel tracks which damage the ground surface and for which continuous rubber tracks are not available.

Bridgestone was first to invent this type of pad and has many years of development and sales experience supplying GEOGRIPs to the construction market.



Easy installation

GEOGRIPs are fitted using four bolts (not included) directly onto the track chain links of the machine undercarriage.

Easy replacement

Individual worn or damaged GEOGRIPs are easily replaced in minutes, thereby reducing downtime.

Kind to road surface

Damage to roads and other surfaces caused by traditional steel shoes is avoided.

Low noise and low vibration

Vibration and noise are reduced compared to steel tracks.

High durability

GEOGRIPs are manufactured using one of Bridgestone's high durability anti-external-cut and anti-chunking rubber compounds. Thanks to Bridgestone's high quality advanced rubber and thick rubber volume, GEOGRIPs provide much higher durability than common clip on type pads.

Design and construction



Pro-Edge

GEOGRIPs use Bridgestone's latest "Pro-Edge" embedded core metals. The special rounded profile wing design combined with the tapered rubber tread lug profile disperse stress concentrations which significantly reduces edge-cut damage caused by riding over curbs or sharp obstacles.



Anti-Cut Rubber Compound

The core metals are embedded in a thick super abrasion-resistant rubber compound which provides a highly robust and durable solution for tracked machines.



Tread Design

GEOGRIP's tread profile is based on Bridgestone's optimized design for high durability, anti-chunking, anti-cut and good turnability.

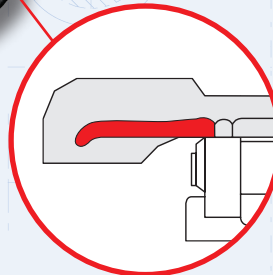

High-Strength Core Metal

GEOGRIP embedded core metals are forged using special treated steel to provide greater strength.



Interlocking Design

GEOGRIP's unique interlocking design reduces the build-up of sand, gravel, rocks and other material or objects in and around the undercarriage, thereby avoiding premature damage.

Advanced Bonding

The embedded core metals are specially treated using high quality bonding agents to ensure **excellent adhesion** between rubber and metal during the vulcanisation process. Bridgestone's advanced bonding technology prolongs the life of GEOGRIP even in harsh operating conditions where rubber removal may be unavoidable.

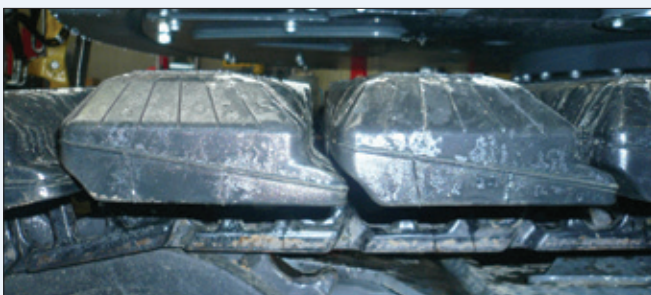

Product Range

Product Code	Dimensions (mm)							Standard Bolt torque (kg-m)	Standard Machine Weight
	Pad Width	A	B	C	D	Bolt Hole Diameter	Link Pitch		
GE250BS	250	110	138	30	38	M12	101.6	10 ± 1.0	up to 2.5 ton
GE400BS	400	80	104	46	45	12.5	135	16.5 ± 1.5	4 to 6.5 ton
GE400CS	400	72	99	43.4	45	13.3	135		
GE400FS	400	66	90	46	45	12.5	135		
GE450AS	450	73	89	57	54	14.5	154	25.0 ± 2.5	6.5 to 10 ton
GE450BS	450	90	90	55	54	14.5	154		
GE450ES	450	83	83	52	54	14.5	140		
GE500BS	500	107.9	107.9	60.32	73	16.5	171.45	42.0 ± 3.0	10 to 15 ton
GE600AS	600	124.4	160.4	62	91	20.5	190	32.0 - 47.0	15 to 30 ton
GE600CS	600	119.6	155.6	69	91	21.1	190		

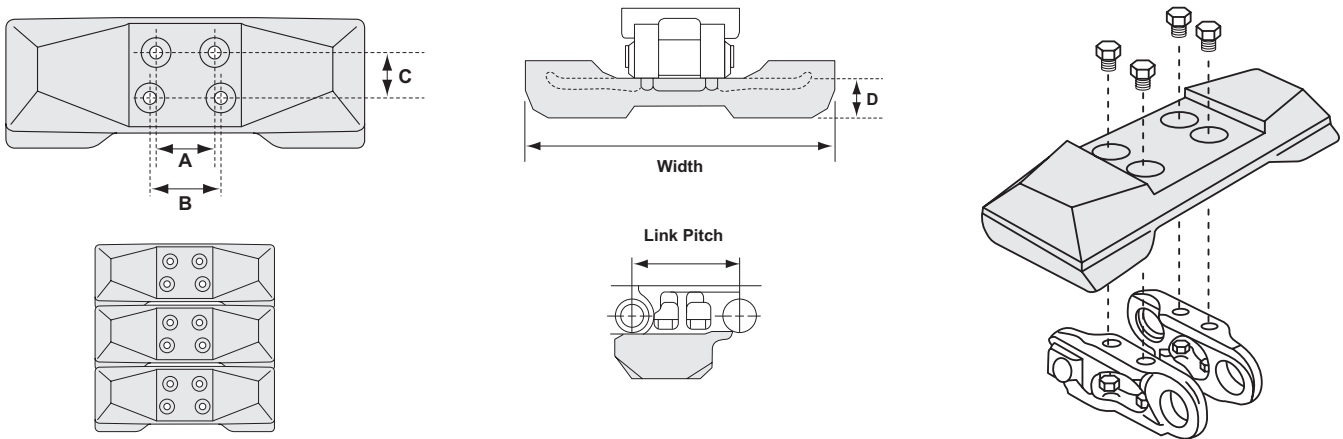

Bridgestone GEOGRIPs are manufactured at facilities recognized for their quality of management by the highest international certification standards:



Bridgestone Quality Management Systems
ISO 9001/2000 Approved



Bridgestone Environmental Management Systems
ISO 14001 Approved

BRIDGESTONE

Your Journey, Our Passion

European Headquarters

Bridgestone Industrial Limited
Berliner Ring 89
64625 Bensheim
Germany
Tel: +49 62 51 8664 0
Fax: +49 62 51 8664 100
www.bridgestoneindustrial.eu

Bridgestone Industrial Limited
Unit 5B
Stour Valley Business Centre
Brundon Lane, Sudbury
Suffolk CO10 7GB, UK
Tel: +44 (0)1787 464502
www.bridgestoneindustrial.eu

Bridgestone Industrial Limited
Galleria Ugo Bassi 1
40121
Bologna
Italy
Tel: +39 051 269190
www.bridgestoneindustrial.eu

Bridgestone Industrial Products
America Inc.
402 Bna Drive, Suite 212
Nashville, TN 37217, USA
Tel: +1 615 365 0600
Fax: +1 615 365 9946
www.bridgestoneindustrial.com

Bridgestone Engineered Products of Asia
Sdn. Bhd. (364273M)
L1-E-3B, Enterprise 4,
Technology Park Malaysia
Lebuhraya Puchong-Sg Besi, Bukit Jalil,
57000 Kuala Lumpur, Malaysia
Tel: +60 3 89962670
Fax: +60 3 89962690

Bridgestone Corporation
Yaesu Centre Building 10F, 1-6-6, Yaesu
Chuo-ku, Tokyo 103-0028 Japan
Tel: +81 3 5202 6881
Fax: +81 3 5202 6719

www.bridgestoneindustrial.eu

The information contained in this publication is for guidance purposes only. While every effort has been made in its production, no responsibility can be accepted for any loss or damage arising from any undetected error. Any data supplied is subject to possible revision following the date of publication. Produced March 2017.